



# DC1103A : 3.5GHz WiMAX Power Amplifier

## Product Description

This product is a linear amplifier operating for IEEE802.16 broadband wireless applications in 3.3 to 3.8GHz. The device is manufactured on InGaP/GaAs HBT process and delivers 30dB gain. It has 2.5% EVM at 24dBm output power from a single +3.3V power supply. It features an integrated detector for antenna power, integrated 20dB step attenuator and on/off power control. No external circuits are required for RF impedance matching, thus reducing external components. It is packaged in a 4x4 QFN style package.

## Typical Application

- WiMAX transceivers
- Fixed Broadband Wireless

## Key Features

- 3.3GHz to 3.8GHz Operation
- 30dB Gain
- 30dBm P1dB @ 3.3V
- 2.5% EVM, Pout=24dBm, 3.3V IEEE802.16OFDM, 64QAM
- Power up/down control < 1us
- Integrated 20dB Step Attenuator
- 50 Ohm Matched RF ports
- On-Chip Power Detector

Parameter	Specification			Unit	Condition
	Min.	Typ.	Max.		
<b>Overall</b>					
Frequency Range	3300		3800	MHz	
OP1dB		30		dBm	Vcc=3.3V
		33		dBm	Vcc=4.5V
Gain		30		dB	
Attenuator Step		20		dB	
NF		7			
IM3		-40		dBc	Pout=19dBm per tone
OIP3		42		dBm	
EVM		2.5		%	Pout=24.0dBm, 802.16OFDM@3.3V
		2.5		%	Pout=27.0dBm, 802.16OFDM@4.5V
Power-Added Efficiency		10		%	Pout=24.0dBm, 802.16OFDM@3.3V,
Power Detector Voltage at 16dBm		+0.5		V	High impedance load
Power Detector Voltage at 30dBm		+2.5		V	
<b>Power Supply</b>					
Power Supply Voltage	3.0	3.3	4.6	V	
Operation Current		300		mA	Pout=24.0dBm, 802.16OFDM@3.3V,
Quiescent Current		180		mA	30% duty cycle.
Turn ON/OFF Time			1	us	

Functional Block Diagram

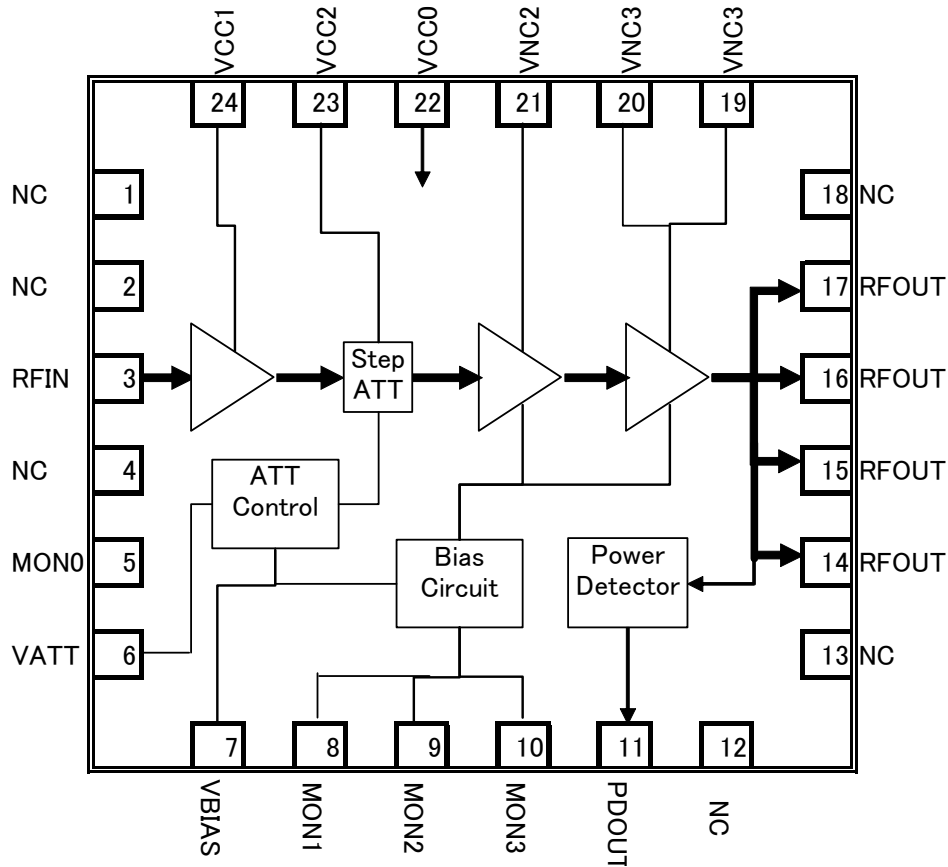

Pin Definitions

PIN No	Name	Descriptions
3	RFIN	RF input PIN. 50 ohm terminated internally.
5	MON0	Bias Monitor 0.(Open)
6	VATT	Step Attenuator Control. ('H'=-20dB, 'L'=0dB)
7	VBIAS	BIAS control and shut down.('H'=-Normal operation, 'L'=Shut Down)
8	MON1	Bias Monitor 1.
9	MON2	Bias Monitor 2.
10	MON3	Bias Monitor 3.
11	PDOUT	Output of Power Detector.
14-17	RFOUT	RF output pins.
19,20	VNC3	Power supply for the Output stage.
21	VNC2	Power supply for the 2nd stage.
22	VCC0	Power supply for Bias Circuit.
23	VCC2	Power supply for Step Attenuator.
24	VCC1	Power Supply for 1st stage.
Pkg Base	GND	The backside of the package should be connected to the ground and provides heat sinking.
1,2,4,12,13,18	NC	These pins are not connected but should be grounded.

Package Outline : QFN 24Pin (4mm x 4mm x 0.8 mm)

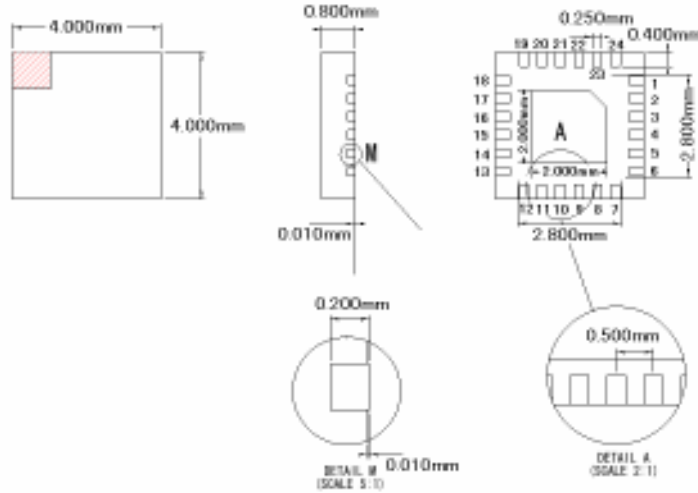

Evaluation Board Schematic

